

Technical data sheet

Title	Ring/ring tensioner
Standard	DIN 1480

1.- Purpose and field of application.

Cable tensioner made up of a ring and another ring, made from forged steel with zinc electroplating.

One of the elements will be threaded on the left and the other on the right. The tensioners will have the metric marked and an "L" if they turn to the left.

The accessory will provide tension by rotating the body of the tensioner until the desired tension is reached.

The tensioners will be chosen according to the eyelet diameter and the load that they have to bear. It is always advisable for the tensioner to work in a straight line or under traction to ensure correct operation.

2. Product dimensions and WLL loads

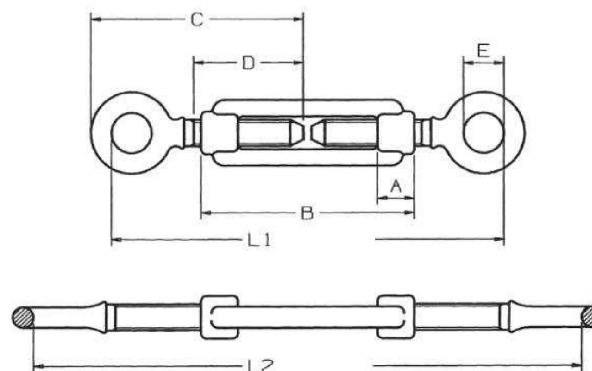

M	A	B	D	E	C	L1	L2	WLL
M5	10	70	36	9	58	110	160	140
M6	12	110	50	9	74	155	235	235
M8	15	110	52	10	80	160	240	320
M10	18	125	60	14	97	200	270	535
M12	21	125	67	16	106	205	270	665
M14	24	140	83	18	126	245	330	1335
M16	27	170	97	22	160	285	390	1665
M20	34	200	116	24	190	315	425	2535
M22	36	220	120	28	200	330	450	2665
M24	39	255	125	28	210	405	570	3665
M30	45	255	150	31	240	450	595	5335
M36	55	295	160	38	276	516	676	8665